

TMC3503

Triple Video D/A Converter

8 bit, 80 Msps

Features

- 8-bit resolution
- 80, 50, and 30 megapixels per second
- ± 0.5 LSB linearity error
- Sync, blank, and white controls
- Independent sync current output
- 1.0V p-p video into 37.5Ω or 75Ω load
- Enhancement of ADV7120
 - Internal bandgap voltage reference
 - Double-buffered data for low distortion
 - Power-down sleep mode
- Double-buffered data for low distortion
- TTL-compatible inputs
- Low glitch energy
- Single +5 Volt power supply

Applications

- Video signal conversion
 - RGB
 - YCbCr
 - Composite, Y, C
- Multimedia systems
- Image processing
- True-color graphics systems
- Broadcast television equipment
- High-Definition Television (HDTV) equipment
- Direct digital synthesis

Description

The TMC3503 is a high-speed triple 8-bit D/A converter especially suited for video and graphics applications. It offers 8-bit resolution, TTL-compatible inputs, low power consumption, a power-down sleep mode, and requires only a single +5 Volt power supply. It has single-ended current outputs, SYNC, BLANK, WHITE, and SLEEP control inputs, and a separate current source for adding sync pulses to any D/A converter output. It is ideal for generating analog RGB

from digital RGB and driving computer display and video monitors. Three speed grades are available: 30, 50, and 80 Msps.

The TMC3503 triple D/A converter is available in a 44-lead plastic J-leaded PLCC. It is fabricated on a sub-micron CMOS process with performance guaranteed from 0°C to 70°C .

Block Diagram

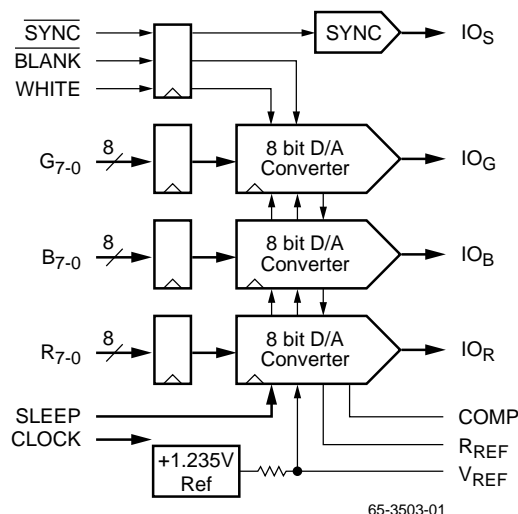

Functional Description

The TMC3503 is a low-cost triple 8-bit CMOS D/A converter designed to directly drive computer CRT displays at pixel rates up to 80 Msps. It comprises three identical 8-bit D/A converters with registered data inputs, common clock, and internal voltage reference. An independent current source allows sync to be added to any D/A converter output.

Digital Inputs

All digital inputs are TTL-compatible. Data are registered on the rising edge of the CLK signal. The analog output changes tDO after the rising edge of CLK. There is one stage of pipeline delay on the chip. The guaranteed clock rates of the TMC3503 are 80, 50, and 30 MHz.

SYNC and BLANK

$\overline{\text{SYNC}}$ and $\overline{\text{BLANK}}$ inputs control the output level (Figure 1 and Table 1) of the D/A converters during CRT retrace intervals. $\overline{\text{BLANK}}$ forces the D/A outputs to the blanking level while $\overline{\text{SYNC}}$ turns off a separate current source which is brought off the chip through the IOS pin.

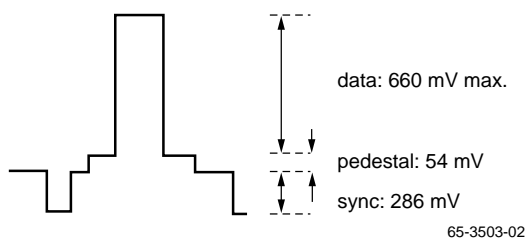

Figure 1. Nominal Output Levels

IOS may be connected to any one D/A output, or used independently. It is commonly tied to the green D/A converter for “Sync on Green” operation. This connection adds a 40 IRE sync pulse to the D/A output and brings that D/A output to 0.0 Volts during the sync tip. $\overline{\text{SYNC}}$ and $\overline{\text{BLANK}}$ are registered on the rising edge of CLK.

$\overline{\text{BLANK}}$ gates the D/A inputs and sets the pedestal voltage. If $\overline{\text{BLANK}} = \text{HIGH}$, the D/A inputs are added to a pedestal which offsets the current output. If $\overline{\text{BLANK}} = \text{LOW}$, data inputs and the pedestal are disabled.

WHITE

The WHITE control drives all three D/As to full-scale, overriding the data inputs. It is overridden by the $\overline{\text{BLANK}}$ input, and is independent of $\overline{\text{SYNC}}$.

SLEEP

The SLEEP control, when HIGH, places the TMC3503 in a power-down state. This function operates asynchronously.

D/A Outputs

Each D/A output is a current source. To obtain a voltage output, a resistor must be connected to ground. Output voltage depends upon this external resistor, the reference voltage, and the value of the gain-setting resistor connected between RREF and GND.

Normally, a source termination resistor of 75 Ohms is connected between the D/A current output pin and GND near the D/A converter. A 75 Ohm coaxial cable may then be connected with another 75 Ohm termination resistor at the far end of the cable. This “double termination” presents the D/A converter with a net resistive load of 37.5 Ohms.

The TMC3503 may also be operated with a single 75 Ohm terminating resistor. To lower the output voltage swing to the desired range, the value of the resistor on RREF should be increased.

Voltage Reference

The TMC3503 has an internal bandgap voltage reference of +1.235 Volts. An external voltage reference may be connected to the VREF pin, overriding the internal voltage reference. All three D/A converters are driven from the same reference.

A 0.1μF capacitor must be connected between the COMP pin and VDD to stabilize internal bias circuitry and ensure low-noise operation.

Power and Ground

The TMC3503 D/A converter requires a single +5.0 Volt power supply. The analog (VDD) power supply voltage should be decoupled to GND to reduce power supply induced noise. 0.1μF decoupling capacitors should be placed as close as possible to the power pins.

The high slew-rate of digital data makes capacitive coupling to the outputs of any D/A converter a potential problem. Since the digital signals contain high-frequency components of the CLK signal, as well as the video output signal, the resulting data feedthrough often looks like harmonic distortion or reduced signal-to-noise performance. All ground pins should be connected to a common solid ground plane for best performance.

Table 1. Output Voltage versus Input Code, SYNC, BLANK, and WHITE

VREF = 1.235 V, RREF = 590 Ω, RL = 37.5 Ω

RGB7-0 (MSB...LSB)	All D/As				D/A with IOS Connected			
	SYNC	BLANK	WHITE	VOUT	SYNC	BLANK	WHITE	VOUT
XXXX XXXX	X	1	1	0.714	1	1	1	1.000
1111 1111	X	1	0	0.714	1	1	0	1.000
1111 1110	X	1	0	0.711	1	1	0	0.997
1111 1101	X	1	0	0.709	1	1	0	0.995
•	•	•	•	•	•	•	•	•
•	•	•	•	•	•	•	•	•
0000 0000	X	1	0	0.385	1	1	0	0.671
1111 1111	X	1	0	0.383	1	1	0	0.669
•	•	•	•	•	•	•	•	•
•	•	•	•	•	•	•	•	•
0000 0010	X	1	0	0.059	1	1	0	0.345
0000 0001	X	1	0	0.057	1	1	0	0.343
0000 0000	X	1	0	0.054	1	1	0	0.340
XXXX XXXX	X	0	X	0.000	1	0	X	0.286
XXXX XXXX	X	0	X	0.000	0	0	X	0.000

Pin Assignments

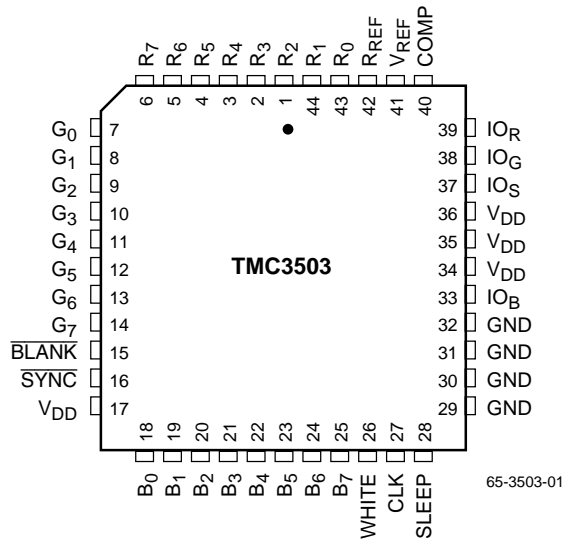

Pin Descriptions

Pin Name	Pin Number	Value	Pin Function Description
Clock and Pixel I/O			
CLK	27	TTL	Clock Input. The clock input is TTL-compatible and all pixel data is registered on the rising edge of CLK. It is recommended that CLK be driven by a dedicated TTL buffer to avoid reflection induced jitter, overshoot, and undershoot.
R7-0 G7-0 B7-0	6-1, 44-43 14-7 25-18	TTL	Red, Green, and Blue Pixel Inputs. The R, G, and B digital inputs are TTL-compatible and registered on the rising edge of CLK.
Controls			
$\overline{\text{SYNC}}$	16	TTL	Sync Pulse Input. Bringing $\overline{\text{SYNC}}$ LOW, turns off a 40 IRE (7.62 mA) current source which forms a sync pulse on any D/A converter output connected to IOS. $\overline{\text{SYNC}}$ is registered on the rising edge of CLK along with pixel data and has the same pipeline latency as $\overline{\text{BLANK}}$ and pixel data. $\overline{\text{SYNC}}$ does not override any other data and should be used only during the blanking interval. If the system does not require sync pulses, $\overline{\text{SYNC}}$ and IOS should be connected to GND.
$\overline{\text{BLANK}}$	15	TTL	Blanking Input. When $\overline{\text{BLANK}}$ is LOW, pixel inputs are ignored and the D/A converter outputs are driven to the blanking level. $\overline{\text{BLANK}}$ is registered on the rising edge of CLK and has the same two-pipe latency as $\overline{\text{SYNC}}$ and Data.
WHITE	26	TTL	Force Full Scale Input. When WHITE is HIGH, pixel inputs are ignored and the D/A converter outputs are driven to their full-scale output level. A BLANK input overwrites a WHITE input. WHITE is register on the rising edge of CLK and has the same two-pipe latency as $\overline{\text{SYNC}}$ and Data.
SLEEP	28	TTL	Power-down Control Input. When HIGH, SLEEP places the D/A converter in a low-power-dissipation mode. The D/A current sources and the digital processing are disabled. The last data loaded into the input and D/A registers is retained. This control is asynchronous.
Video Outputs			
IOR IOG IOB	39 38 33	0.714 V _{p-p}	Red, Green, and Blue Data Outputs. The current source outputs of the D/A converters are capable of driving RS-343A/SMPTE-170M compatible levels into doubly-terminated 75 Ohm lines. Sync pulses may be added to any D/A output.
IOS	37	0.714 V _{p-p}	SYNC Current Output. When this pin is connected to any of the D/A converter outputs, a 40 IRE offset is added to the video level. When the $\overline{\text{SYNC}}$ input is LOW, the current is turned off, bring the sync tip voltage to 0.0V. If no sync pulse is required, IOS should be grounded. When $\overline{\text{SYNC}}$ is HIGH, the current flowing out of IOS is: IOS = 3.64 (VREF / RREF)
Voltage Reference			
VREF	41	+1.235 V	Voltage Reference Input/Output. An internal voltage source of +1.235 Volts is output on this pin. An external +1.235 Volt reference may be applied here which overrides the internal reference. Decoupling VREF to GND with a 0.1μF ceramic capacitor is required.

Pin Descriptions (continued)

Pin Name	Pin Number	Value	Pin Function Description
RREF	42	590 Ω	<p>Current-setting Resistor. The full-scale output current of each D/A converter is determined by the value of the resistor connected between RREF and GND. The nominal value for RREF is found from:</p> $R_{REF} = 9.1 (V_{REF}/I_{FS})$ <p>where I_{FS} is the full-scale (white) output current (amps) from the D/A converter (without sync). Sync is $0.4 I_{FS}$.</p> <p>D/A full-scale (white) current may also be calculated from:</p> $I_{FS} = V_{FS}/R_L$ <p>Where V_{FS} is the white voltage level and R_L is the total resistive load (ohms) on each D/A converter. V_{FS} is the blank to full-scale voltage.</p>
COMP	40	0.1 μF	<p>Compensation Capacitor. A 0.1 μF ceramic capacitor must be connected between COMP and VDD to stabilize internal bias circuitry.</p>
Power, Ground			
VDD	17, 34–36	+5 V	Power Supply.
GND	29–32	0.0V	Ground.

Equivalent Circuits

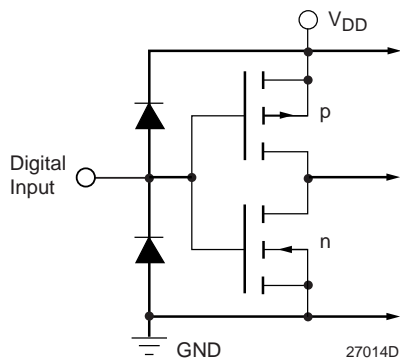

Figure 2. Equivalent Digital Input Circuit

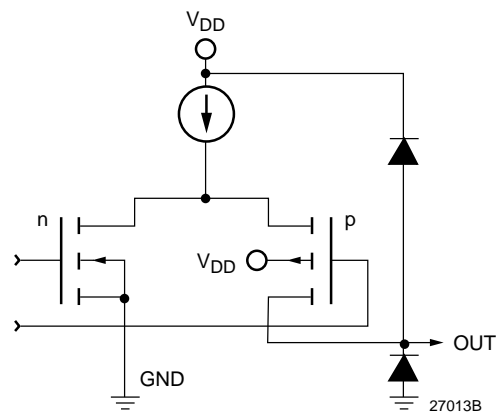

Figure 3. Equivalent Analog Output Circuit

Equivalent Circuits (continued)

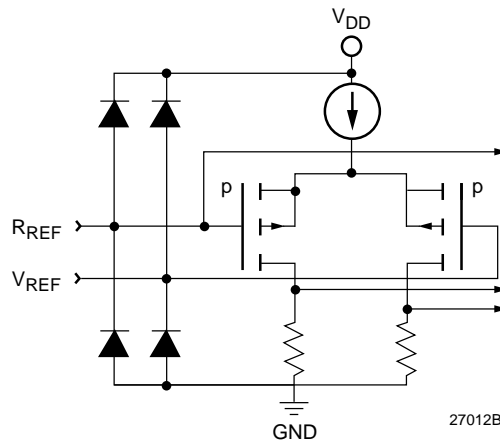

Figure 4. Equivalent Analog Input Circuit

Absolute Maximum Ratings (beyond which the device may be damaged)¹

Parameter	Min	Typ	Max	Unit
Power Supply Voltage				
V _{DD} (Measured to GND)	-0.5		7.0	V
Inputs				
Applied Voltage (measured to GND) ²	-0.5		V _{DD} + 0.5	V
Forced Current ^{3,4}	-10.0		10.0	mA
Outputs				
Applied Voltage (measured to GND) ²	-0.5		V _{DD} + 0.5	V
Forced Current ^{3,4}	-60.0		60.0	mA
Short Circuit Duration (single output in HIGH state to ground)			infinite	second
Temperature				
Operating, Ambient	-20		110	°C
Junction			150	°C
Lead Soldering (10 seconds)			300	°C
Vapor Phase Soldering (1 minute)			220	°C
Storage	-65		150	°C

Notes:

1. Functional operation under any of these conditions is NOT implied. Performance and reliability are guaranteed only if Operating Conditions are not exceeded.
2. Applied voltage must be current limited to specified range.
3. Forcing voltage must be limited to specified range.
4. Current is specified as conventional current flowing into the device.

Operating Conditions

Parameter			Min	Nom	Max	Units
V _{DD}	Power Supply Voltage		4.75	5.0	5.25	V
f _S	Conversion Rate	TMC3503-30			30	MSPS
		TMC3503-50			50	MSPS
		TMC3503-80			80	MSPS
t _{PWH}	CLK Pulsewidth, HIGH		4			ns
t _{PWL}	CLK Pulsewidth, LOW		4			ns
t _S	Input Data Setup Time		3			ns
t _H	Input Data Hold Time		2			ns
V _{REF}	Reference Voltage, External		1.0	1.235	1.5	V
C _C	Compensation Capacitor			0.1		μF
R _L	Output Load			37.5		Ω
V _{IH}	Input Voltage, Logic HIGH		2.0		V _{DD}	V
V _{IL}	Input Voltage, Logic LOW		GND		0.8	V
T _A	Ambient Temperature, Still Air		0		70	°C

Electrical Characteristics

Parameter		Conditions ³	Min	Typ ¹	Max	Units
I _{DD}	Power Supply Current ²	V _{DD} = Max				
		TMC3503-30			100	mA
		TMC3503-50			100	mA
		TMC3503-80			125	mA
I _{DDs}	Power Supply Current, Sleep Mode	V _{DD} = Max			3	mA
P _D	Total Power Dissipation ²	V _{DD} = Max				
		TMC3503-30			525	mW
		TMC3503-50			525	mW
		TMC3503-80			655	mW
R _O	Output Resistance			100		kΩ
C _O	Output Capacitance	I _{OUT} = 0mA			30	pF
I _{IH}	Input Current, HIGH	V _{DD} = Max, V _{IN} = 2.4V			-1	μA
I _{IL}	Input Current, LOW	V _{DD} = Max, V _{IN} = 0.4V			1	μA
I _{REF}	V _{REF} Input Bias Current			0	±100	μA
V _{REF}	Reference Voltage Output			1.235		V
V _{OC}	Output Compliance	Referred to V _{DD}	-0.4	0	+1.5	V
C _{DI}	Digital Input Capacitance			4	10	pF

Notes:

1. Values shown in Typ column are typical for V_{DD} = +5V and T_A = 25°C
2. Minimum/Maximum values with V_{DD} = Max and T_A = Min
3. V_{REF} = 1.235V, R_{LOAD} = 37.5Ω, R_{REF} = 590Ω

Switching Characteristics

Parameter		Conditions ²	Min	Typ ¹	Max	Units
t _D	Clock to Output Delay	V _{DD} = Min		10	15	ns
t _{SKEW}	Output Skew			1	2	ns
t _R	Output Risetime	10% to 90% of Full Scale		2	3	ns
t _F	Output Falltime	90% to 10% of Full Scale		2	3	ns
t _{SET}	Output Settling Time	to 3%/FS		15		ns

Notes:

1. Values shown in Typ column are typical for V_{DD} = +5V and T_A = 25°C.
2. V_{REF} = 1.235V, R_{LOAD} = 37.5Ω, R_{REF} = 590Ω.

System Performance Characteristics

Parameter		Conditions ²	Min	Typ ¹	Max	Units
ELI	Integral Linearity Error	V _{DD} , V _{REF} = Nom		±0.2	±0.3	%/FS
ELD	Differential Linearity Error	V _{DD} , V _{REF} = Nom		±0.2	±0.3	%/FS
EDM	DAC to DAC Matching	V _{DD} , V _{REF} = Nom		3	10	%
EG	Absolute Gain Error	V _{DD} , V _{REF} = Nom			TBD	%/FS
TCEG	Gain Error Tempco	V _{DD} , V _{REF} = Nom		TBD		PPM/°C
VOF	Output Offset Current	V _{DD} = Max, R, G, B = 000h SYNC = BLANK = 0			20	mA
PSRR	Power Supply Rejection Ratio				0.05	%/%

Notes:

1. Values shown in Typ column are typical for V_{DD} = +5V and T_A = 25°C.
2. V_{REF} = 1.235V, R_{LOAD} = 37.5Ω, R_{REF} = 590Ω.

Timing Diagram

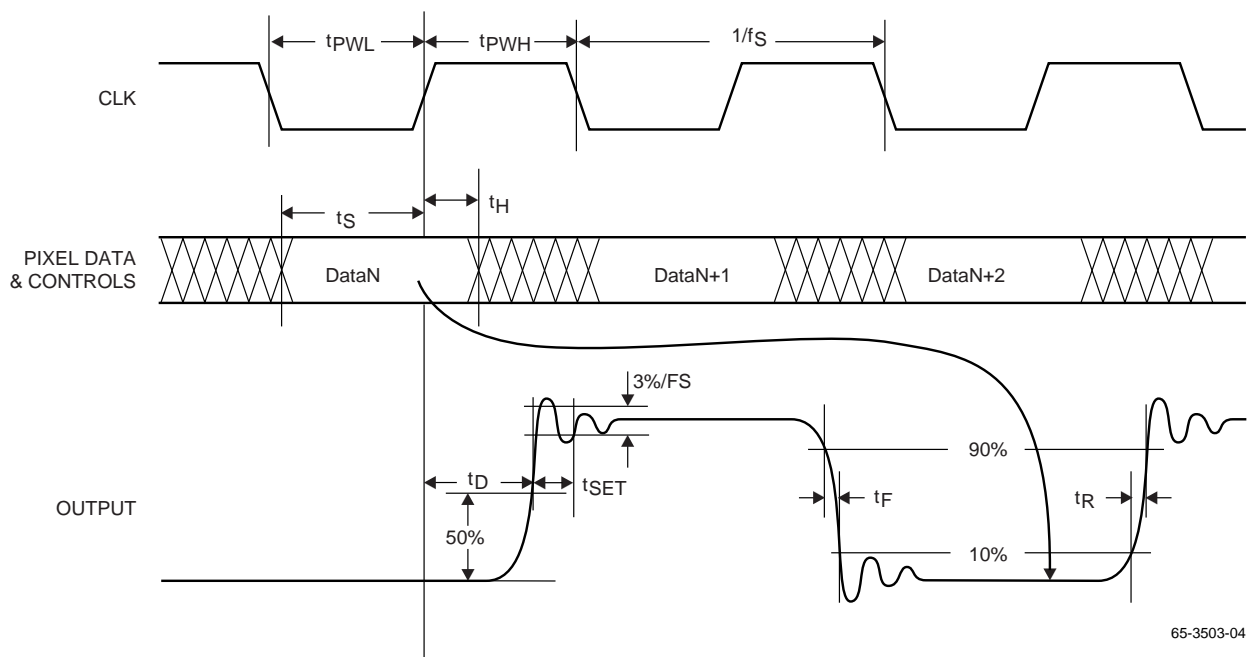

65-3503-04

Application Notes

Figure 4 illustrates a typical TMC3503 interface circuit. In this example, an optional 1.2 Volt bandgap reference is connected to the VREF output, overriding the internal voltage reference source.

Grounding

It is important that the TMC3503 power supply is well-regulated and free of high-frequency noise. Careful power supply decoupling will ensure the highest quality video signals at the output of the circuit. The TMC3503 has separate analog and digital circuits. To keep digital system noise from the D/A converter, it is recommended that power supply voltages (VDD) come from the system analog power source and all ground connections (GND) be made to the analog ground plane. Power supply pins should be individually decoupled at the pin.

Printed Circuit Board Layout

Designing with high-performance mixed-signal circuits demands printed circuits with ground planes. Overall system performance is strongly influenced by the board layout. Capacitive coupling from digital to analog circuits may result in poor D/A conversion. Consider the following suggestions when doing the layout:

1. Keep the critical analog traces (VREF, IREF, COMP, IOS, IOR, IOG, IOB) as short as possible and as far as possible from all digital signals. The TMC3503 should be located near the board edge, close to the analog output connectors.
2. The power plane for the TMC3503 should be separate from that which supplies the digital circuitry. A single power plane should be used for all of the VDD pins. If the power supply for the TMC3503 is the same as that of the system's digital circuitry, power to the TMC3503 should be decoupled with 0.1 μ F and 0.01 μ F capacitors and isolated with a ferrite bead.
3. The ground plane should be solid, not cross-hatched. Connections to the ground plane should have very short leads.
4. If the digital power supply has a dedicated power plane layer, it should not be placed under the TMC3503, the voltage reference, or the analog outputs. Capacitive coupling of digital power supply noise from this layer to the TMC3503 and its related analog circuitry can have an adverse effect on performance.
5. CLK should be handled carefully. Jitter and noise on this clock will degrade performance. Terminate the clock line carefully to eliminate overshoot and ringing.

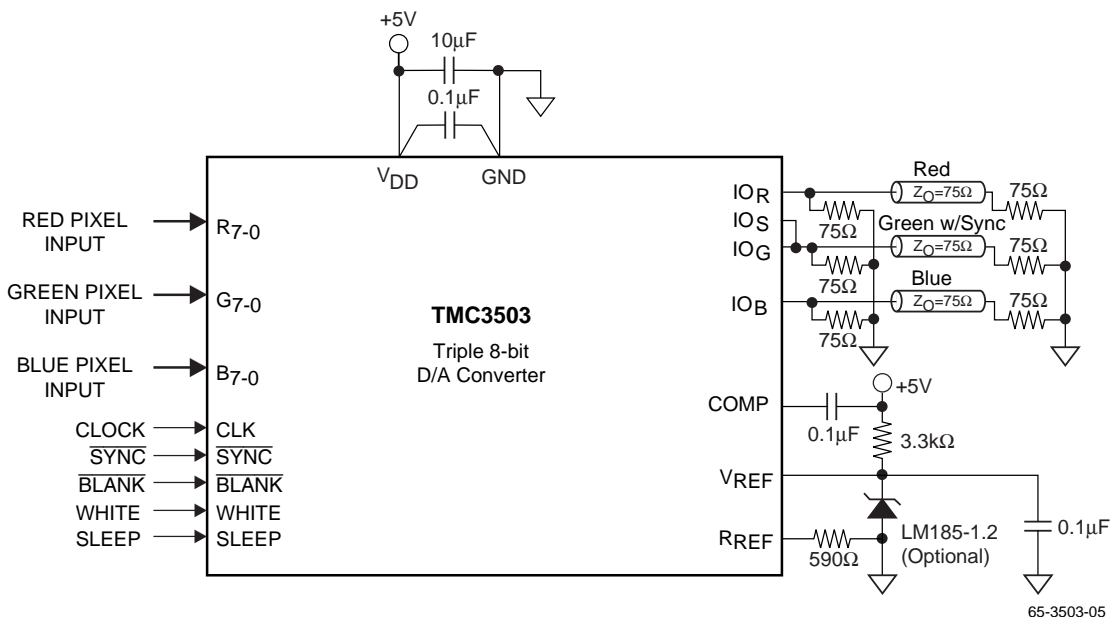

Figure 4. Typical Interface Circuit

Related Products

- TMC3003 Triple 10-bit 80 Msps D/A Converter
- TMC1175A 40 Msps CMOS 8-bit A/D Converter
- TMC1275 40 Msps CMOS 8-bit A/D Converter
- TMC22091, TMC22191 Digital Video Encoders
- TMC2242A/TMC2243/TMC2246A Video Filters
- TMC2249A Digital Mixer
- TMC2250A Matrix Multiplier
- TMC2272A Colorspace Converter
- TMC2302 Image Manipulation Sequencer
- TMC2340A Digital Synthesizer
- TMC2081 Digital Video Mixer

Mechanical Dimensions – 44-pin PLCC Package

Symbol	Inches		Millimeters		Notes
	Min.	Max.	Min.	Max.	
A	.165	.180	4.19	4.57	
A1	.090	.120	2.29	3.05	
A2	.020	—	.51	—	
B	.013	.021	.33	.53	
B1	.026	.032	.66	.81	
D/E	.685	.695	17.40	17.65	
D1/E1	.650	.656	16.51	16.66	3
D3/E3	.500 BSC		12.7 BSC		
e	.050 BSC		1.27 BSC		
J	.042	.056	1.07	1.42	2
ND/NE	11		11		
N	44		44		
ccc	—	.004	—	0.10	

Notes:

1. All dimensions and tolerances conform to ANSI Y14.5M-1982
2. Corner and edge chamfer (J) = 45°
3. Dimension D1 and E1 do not include mold protrusion. Allowable protrusion is .101" (.25mm)

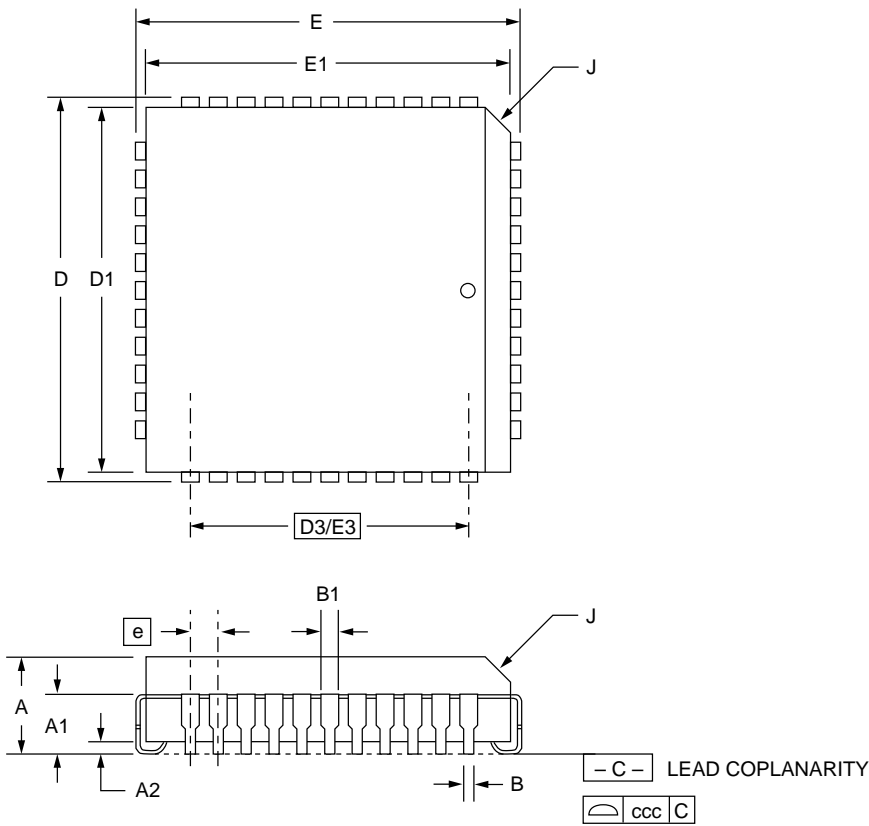

Ordering Information

Product Number	Conversion Rate (Msps)	Temperature Range	Screening	Package	Package Marking
TMC3503R2C30	30 Msps	T _A = 0°C to 70°C	Commercial	44-Lead PLCC	3503R2C30
TMC3503R2C50	50 Msps	T _A = 0°C to 70°C	Commercial	44-Lead PLCC	3503R2C50
TMC3503R2C80	80 Msps	T _A = 0°C to 70°C	Commercial	44-Lead PLCC	3503R2C80

The information contained in this data sheet has been carefully compiled; however, it shall not by implication or otherwise become part of the terms and conditions of any subsequent sale. Raytheon's liability shall be determined solely by its standard terms and conditions of sale. No representation as to application or use or that the circuits are either licensed or free from patent infringement is intended or implied. Raytheon reserves the right to change the circuitry and any other data at any time without notice and assumes no liability for errors.

LIFE SUPPORT POLICY:

Raytheon's products are not designed for use in life support applications, wherein a failure or malfunction of the component can reasonably be expected to result in personal injury. The user of Raytheon components in life support applications assumes all risk of such use and indemnifies Raytheon Company against all damages.

Raytheon Electronics
Semiconductor Division
5580 Morehouse Drive
San Diego, CA 92121
619 457 1000
800 722 7074
Fax 619 455 6314
applications@lj.sd.ray.com